

# HANGING BASKET DISPLAY STAND (4 ARM)

DATA SHEET

FRONT

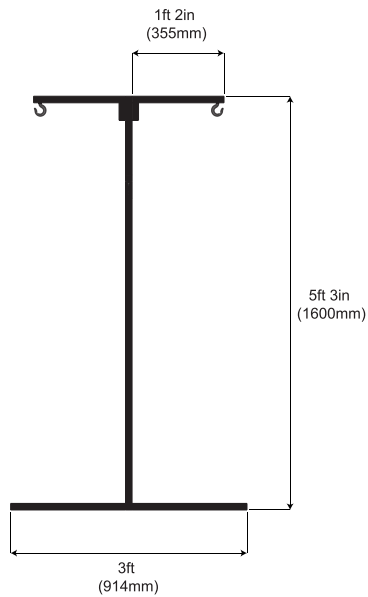

SIDE

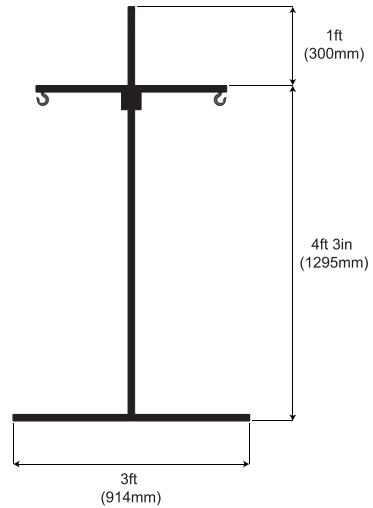

TOP

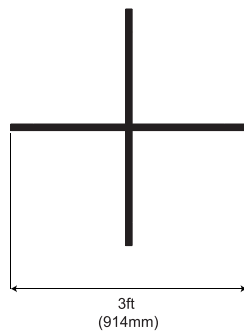

ASSEMBLY

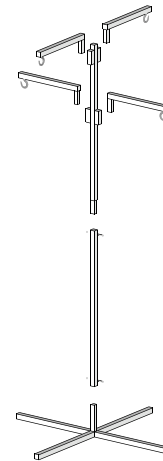

Flower Hanging Basket Display Stand Specification (4 Arm)		
Size	3ft x 3ft 6in x 5ft 3in (914mm x 914mm x 1600mm) — length x width x height	
Footprint	3ft x 3ft (914mm x 914mm)	
Weight	Frame (steelwork only)	7kg
Number of parts	Frame	7 pieces
Longest unbroken length	3ft x 3ft base (914mm)	
Warranty	5 years	
Materials used	Frame	1in x 1in (25mm x 25mm) steel box section, 2mm wall thickness
	Finish options	Black spray paint Silver zinc plate, clear passivation Powder coat (various colours)
Estimated assembly time	1 minute (1 person)	
Typical uses	Ideal for retail and home environments, for indoor and outdoor use	

**CAUTION: You must ensure you have fully read the enclosed safety guidelines before attempting to assemble or use this product**



## WARNING

---

- ✗ **Do not** climb on framework.
- ✗ **Do not** use a steel hammer to assemble framework, doing so may cause damage to surface finishes or bodily injury.  
*Note: no specialist tools are required to assemble this product but if so required, use a rubber or wooden mallet only.*
- ✗ **Do not** assemble framework on a steep incline. Assemble on level ground only.

- ! When new, the framework assembly may be stiff. This stiffness will ease with regular use.
- ! When new, the framework of this product may contain loose metal filings. Be careful when first assembling.
- ! When new, oil residue may be present around connection points. Be careful when first assembling.
- ! Always ensure wheel brakes are engaged when the stand is stationary. Do not leave the stand unattended if wheel brakes are not engaged.



## DISCLAIMER

---

### **Read this before setting up or using your Gavin Kenning Engineering Limited product.**

Improper use of this product and/or its components can cause damage to equipment or property, serious personal injury or death.

Gavin Kenning Engineering Limited shall not be liable for any damages arising out of the use of this product, including, but not limited to, damages for economic loss of profits or savings, lost wages; damages to or loss of use of property; bodily injury; medical payments; pain and suffering; and loss of consortium.

### **LIMITED WARRANTY FOR NEW GAVIN KENNING ENGINEERING LTD DISPLAY STANDS**

---

#### **WHAT IS WARRANTED**

All components of this display stand are covered by a limited 60-month warranty and are warranted free from defects in material and workmanship for a period of 60 months from the date of purchase. The warranty is valid as of the day of purchase and a dated proof of purchase should be presented upon request.

#### **WHAT IS NOT WARRANTED – GAVIN KENNING ENGINEERING LTD IS NOT RESPONSIBLE FOR THE FOLLOWING:**

Normal wear and tear and/or damage caused by use of force, incorrect handling, inappropriate use, neglect, alteration, assembly not in accordance with the manual or improper anchoring. Gavin Kenning Engineering Ltd have no obligation whatsoever to repair, replace, adjust or otherwise compensate the purchaser if this display stand sustains damage and malfunctions as a result of misuse, abuse, negligence, accident, a lack of proper maintenance, impact by foreign objects, storms, floods, pollutants, chemicals, acts of God or any other cause outside the control of Gavin Kenning Engineering Ltd.

#### **WARRANTY SERVICE**

For customer assistance with warranty claims please contact Gavin Kenning Engineering Ltd by phone: 01773 607505, by email: sales@tradersupplies.co.uk or by post: Gavin Kenning Engineering Ltd, Units 1-4 Keys Road, Nix's Hill Industrial Estate, Somercotes, Derbyshire, DE55 7FQ.

In all communications proof of purchase will be required along with a description and photograph of the claimed defect.

#### **LIMITATION OF IMPLIED WARRANTIES**

Gavin Kenning Engineering Ltd will not have other or greater liability for defects in the product, nor will Gavin Kenning Engineering Ltd have any liability for incidental, special or consequential damages of any kind whether for breach of any express written or oral or implied warranty on products, breach of contract, negligence, misrepresentation, or otherwise, and whether resulting in lost profits, loss of investment or interest on investment, work stoppage or otherwise. Your exclusive remedy shall be enforcement of this warranty upon the terms and conditions herein contained. No representative of Gavin Kenning Engineering Ltd or its distributors is authorised to make any change or modification to this warranty.